

UFO Doctor and Miru, Oct. 29th, 2015

1.Introduction

The RC Receiver Orange R615X needs only a 3-wire cable to an ICSP of a uC!

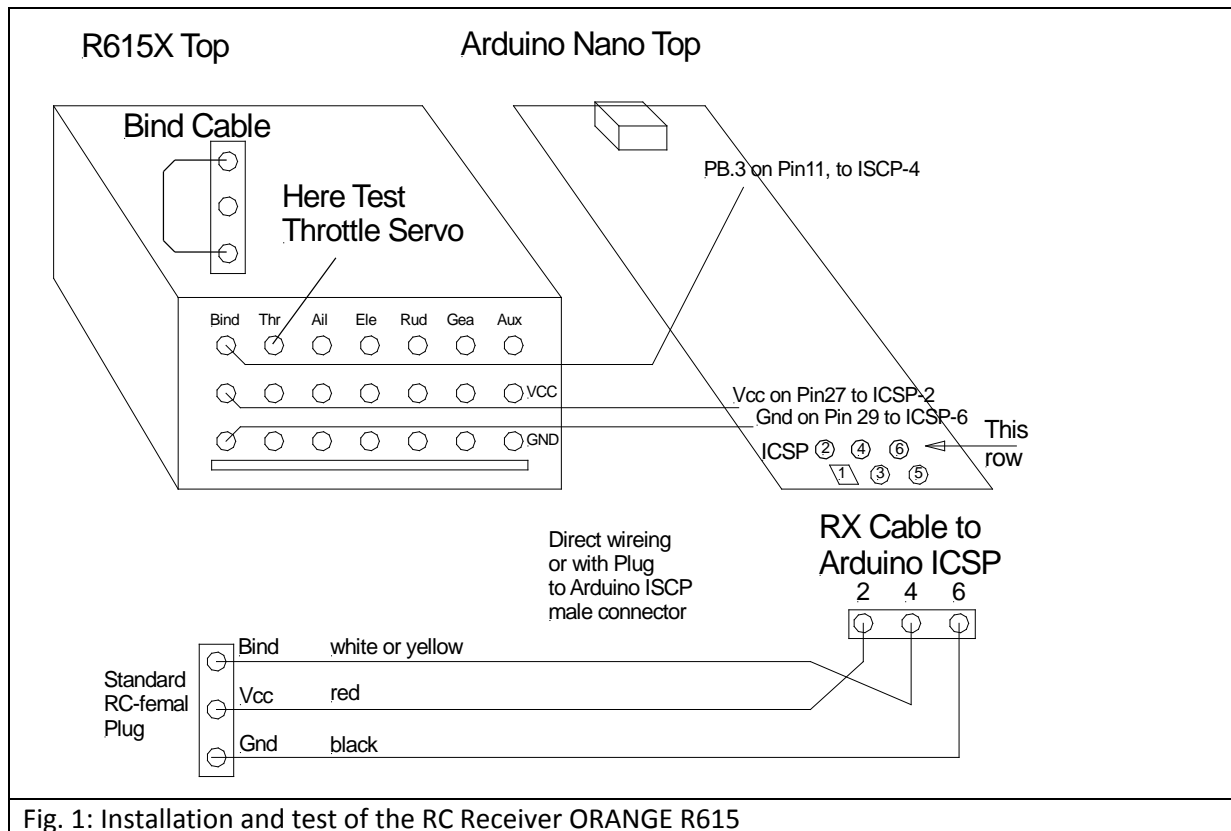

Fig. 1: Installation and test of the RC Receiver ORANGE R615

2. Binding Procedure:

- 1: Switch TX on: Select Servo Adjust: Set throttle to -125% (better, if possible to -150%!)
 - 2: Change the RX cable form slot "Bind" to slot "Thr" for Orange R615X supply
 - 3: Plug Bind Cable into slot "Bind"
 - 4: Place your RC-TX at least 1 Meter away from R615X
 - 5: Press Throttle Stick "full down" and Bind Stick "active" permanently and turn TX on
 - 6: Observe the LED of the ORANGERX R615X: Blinking to solid light after about 15 sec
 - 7: Switch TX and RX off
 8. Remove the Bind Cable, Plug-in the RX cable at "Bind", Plug-in a test servo at "Thr"
 - 9: Switch TX on: Set Servo adjust throttle negative back to -100%
 - 10: Switch RX on: Check throttle servo function
 - 11: Switch TX off: Throttle Servo should turn to its ZERO position